



(19) **United States**

(12) **Patent Application Publication**
Yao et al.

(10) **Pub. No.: US 2007/0152567 A1**
(43) **Pub. Date: Jul. 5, 2007**

(54) **PIXEL STRUCTURE, ORGANIC ELECTRO-LUMINESCENCE DISPLAYING UNIT AND REPAIRING METHOD THEREOF**

Publication Classification

(51) **Int. Cl.**
G09G 3/10 (2006.01)
H01J 1/62 (2006.01)
(52) **U.S. Cl.** **313/504**; 313/506; 315/169.3; 313/498; 313/505

(76) Inventors: **Chih-Wen Yao**, Hsinchu City (TW); **Hsin-Hung Lee**, Taipei (TW)

Correspondence Address:
JIANQ CHYUN INTELLECTUAL PROPERTY OFFICE
7 FLOOR-1, NO. 100, ROOSEVELT ROAD, SECTION 2
TAIPEI 100

(57) **ABSTRACT**

A pixel structure electrically connected to a scan line, a data line and a power line is provided. The pixel structure includes a current control unit, a pixel electrode and a redundant active device. The current control unit is electrically connected to the scan line, the data line and the power line. The pixel electrode is electrically connected to the current control unit. The redundant active device is electrically connected to the pixel electrode and the current control unit, and the redundant active device is electrically insulated from the power line. Moreover, an organic electro-luminescence displaying unit and a repairing method thereof are further provided.

(21) Appl. No.: **11/309,018**

(22) Filed: **Jun. 9, 2006**

(30) **Foreign Application Priority Data**

Jan. 2, 2006 (TW) 95100056

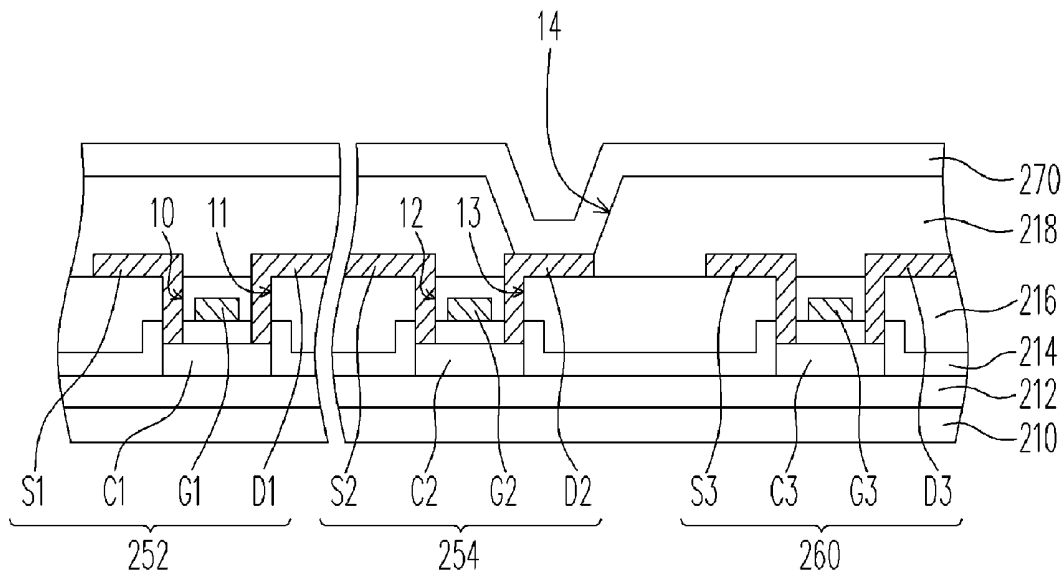

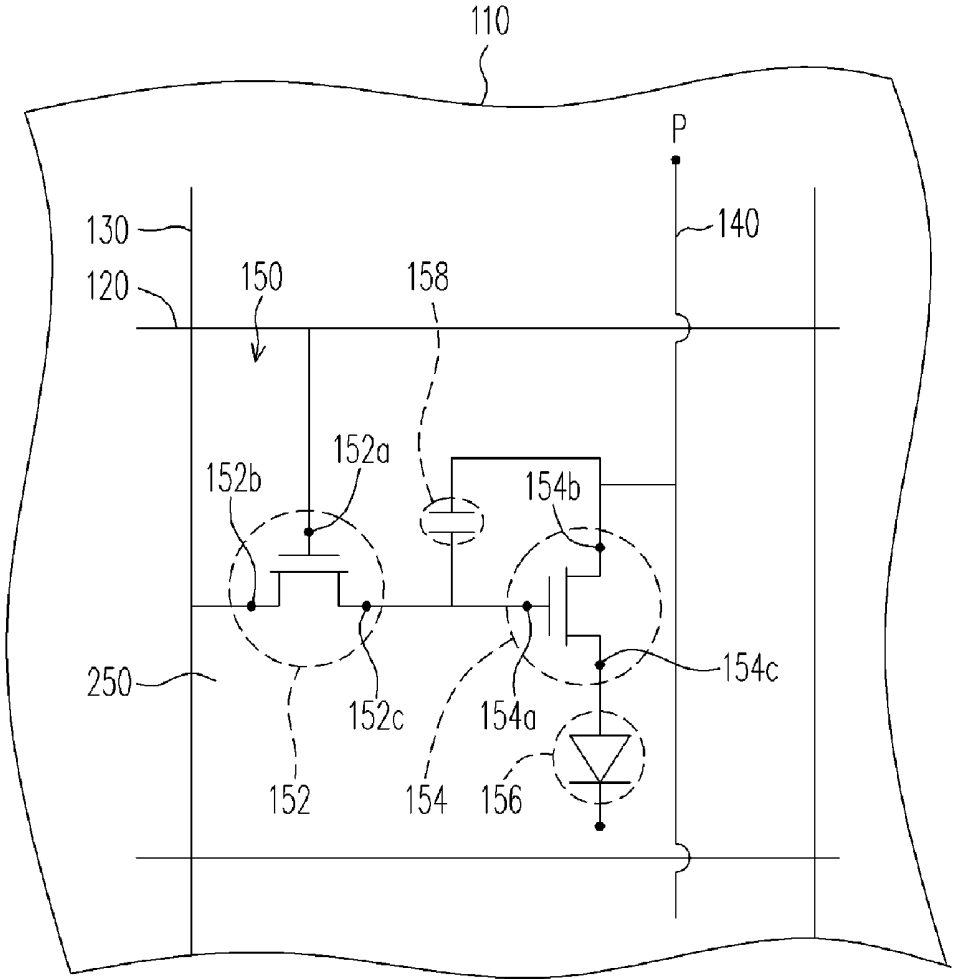

100

FIG. 1 (PRIOR ART)

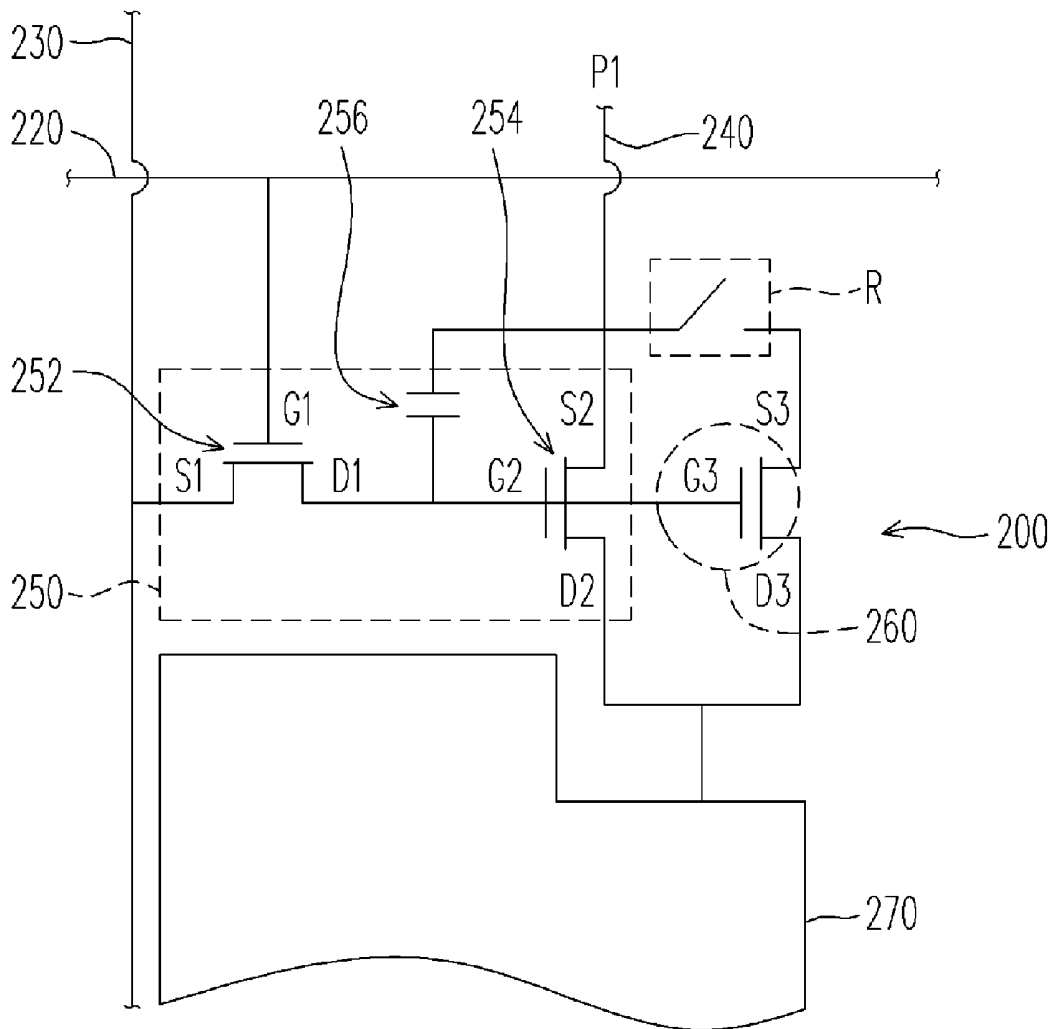

FIG. 2

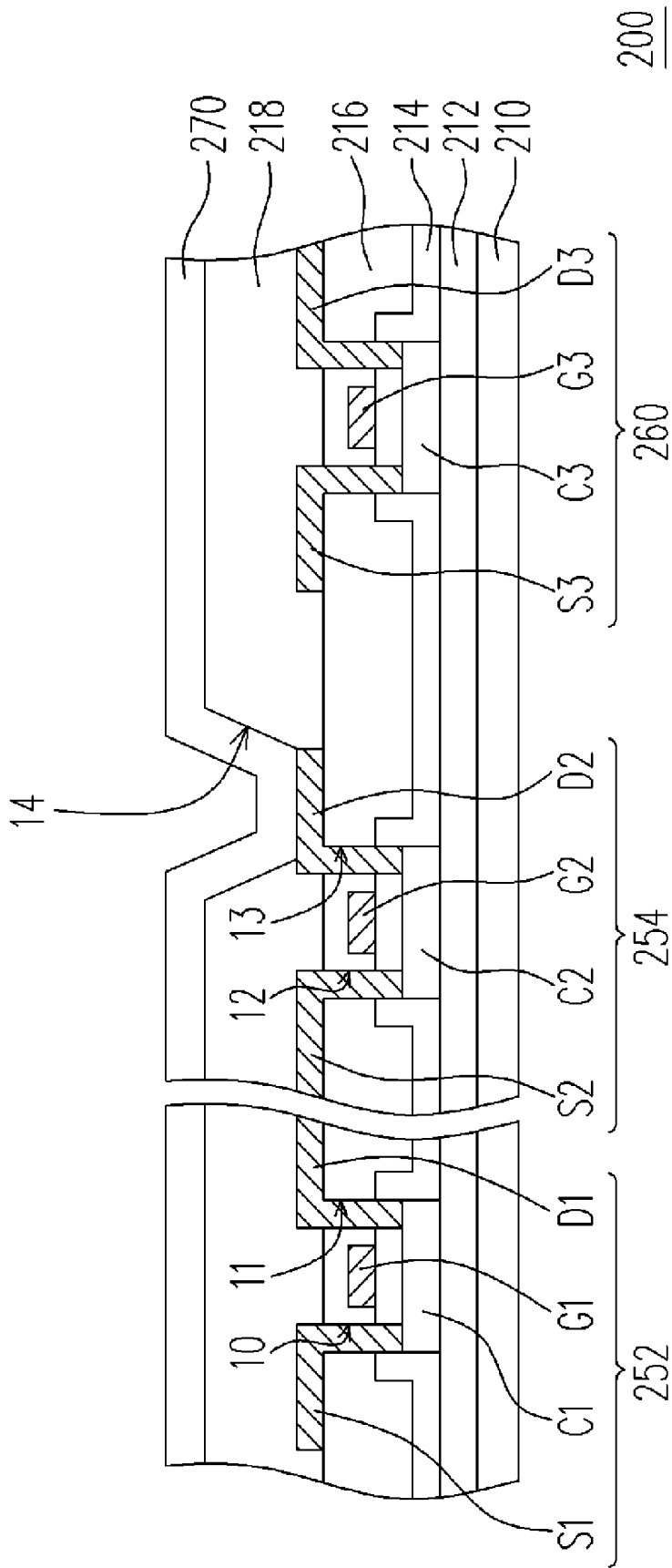

FIG. 3

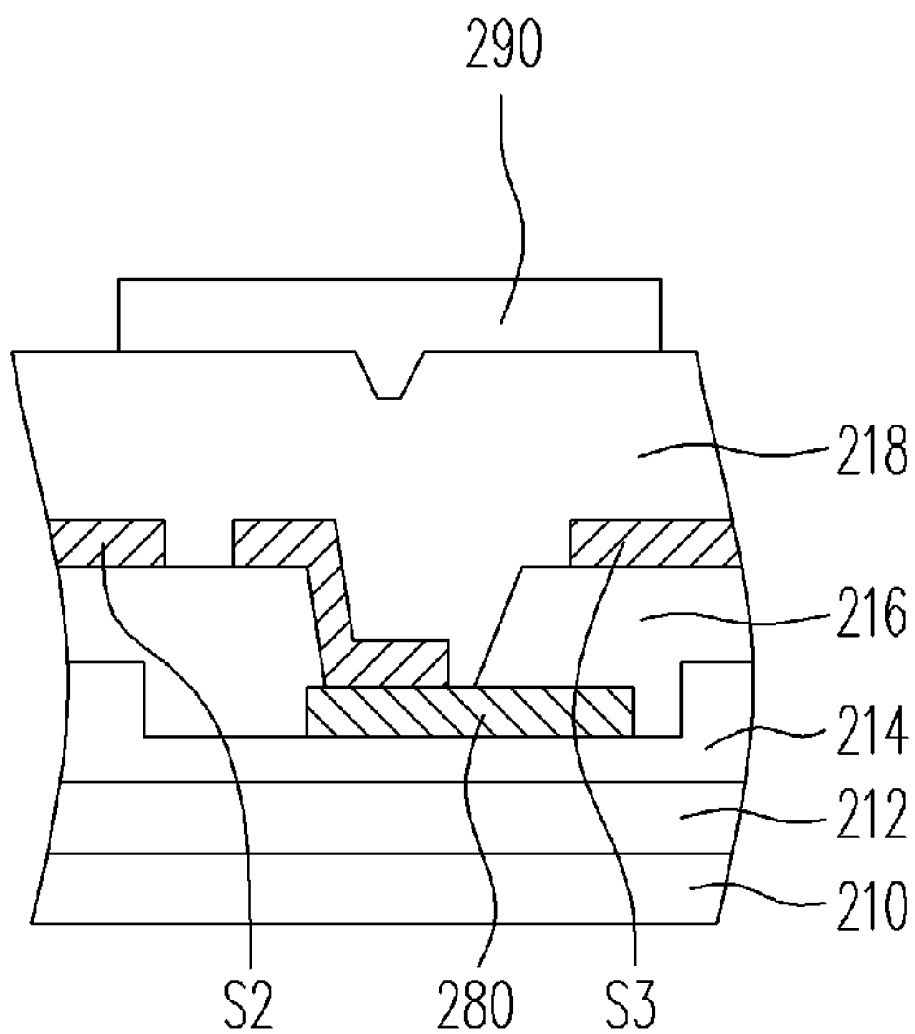

FIG. 4

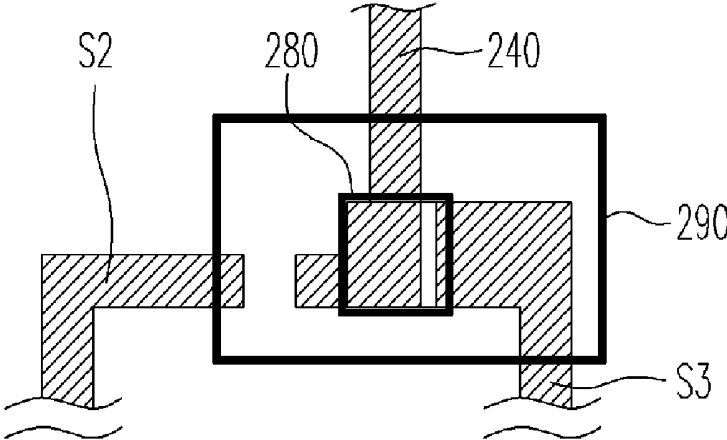

FIG. 5A

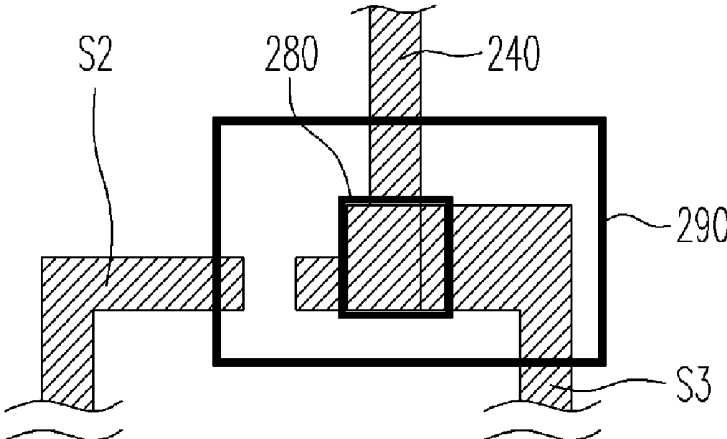

FIG. 5B

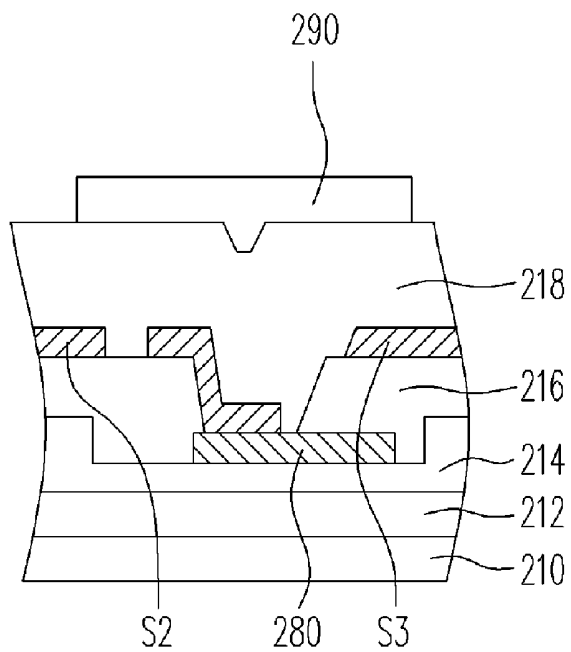

FIG. 6A

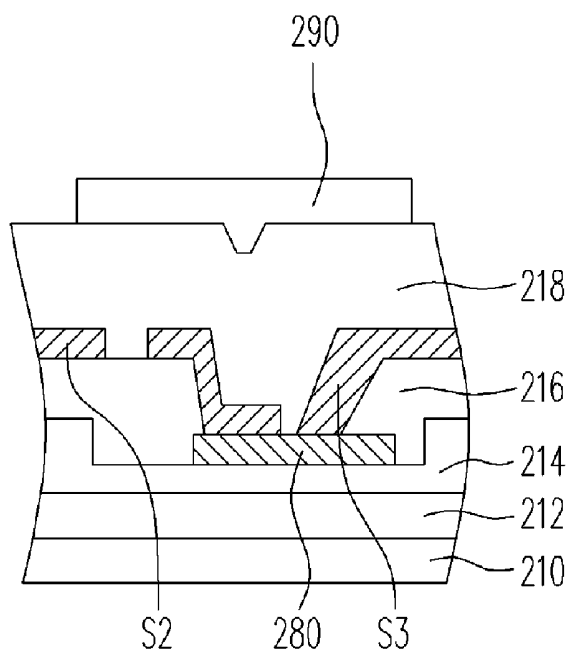

FIG. 6B

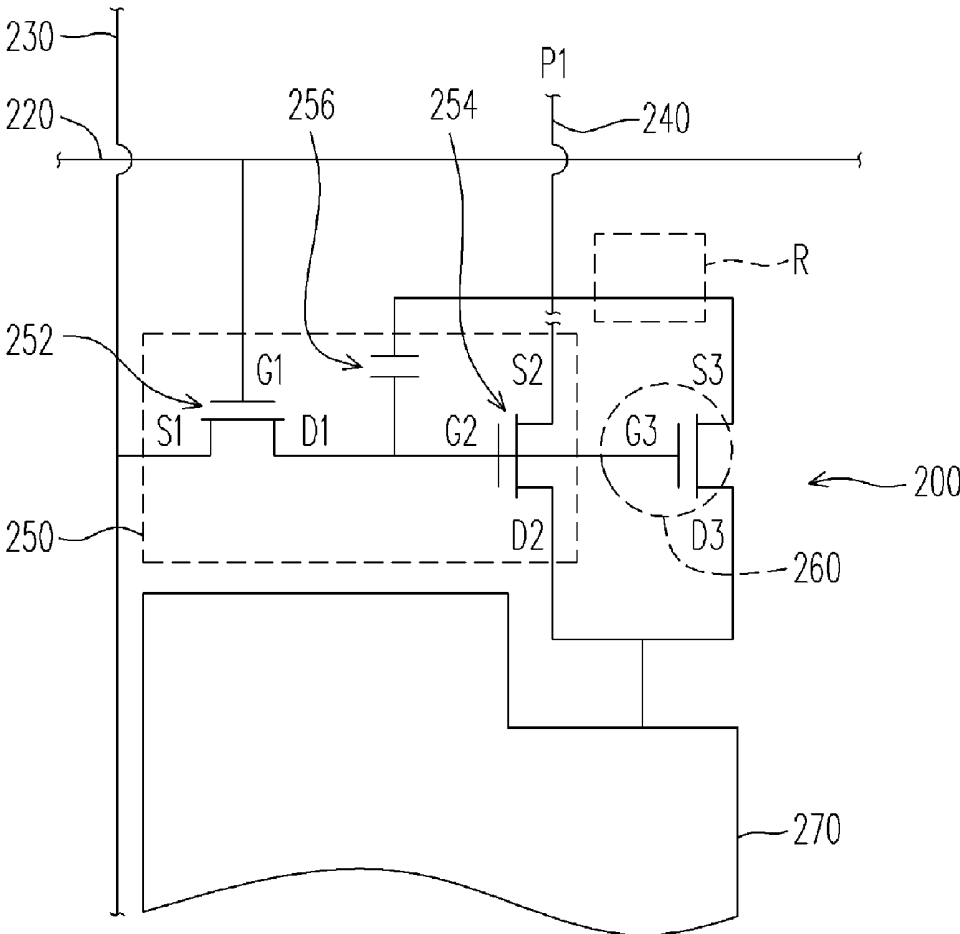

FIG. 7

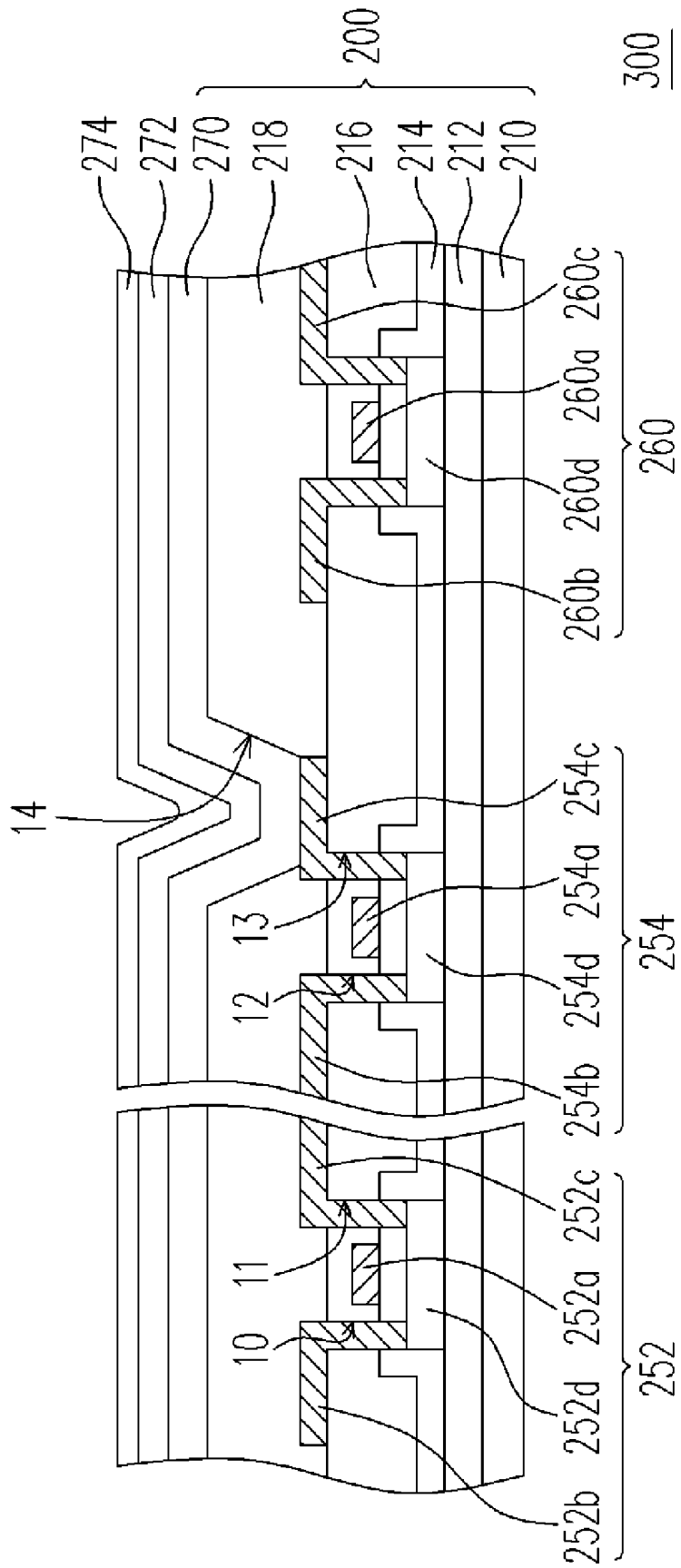

FIG. 8

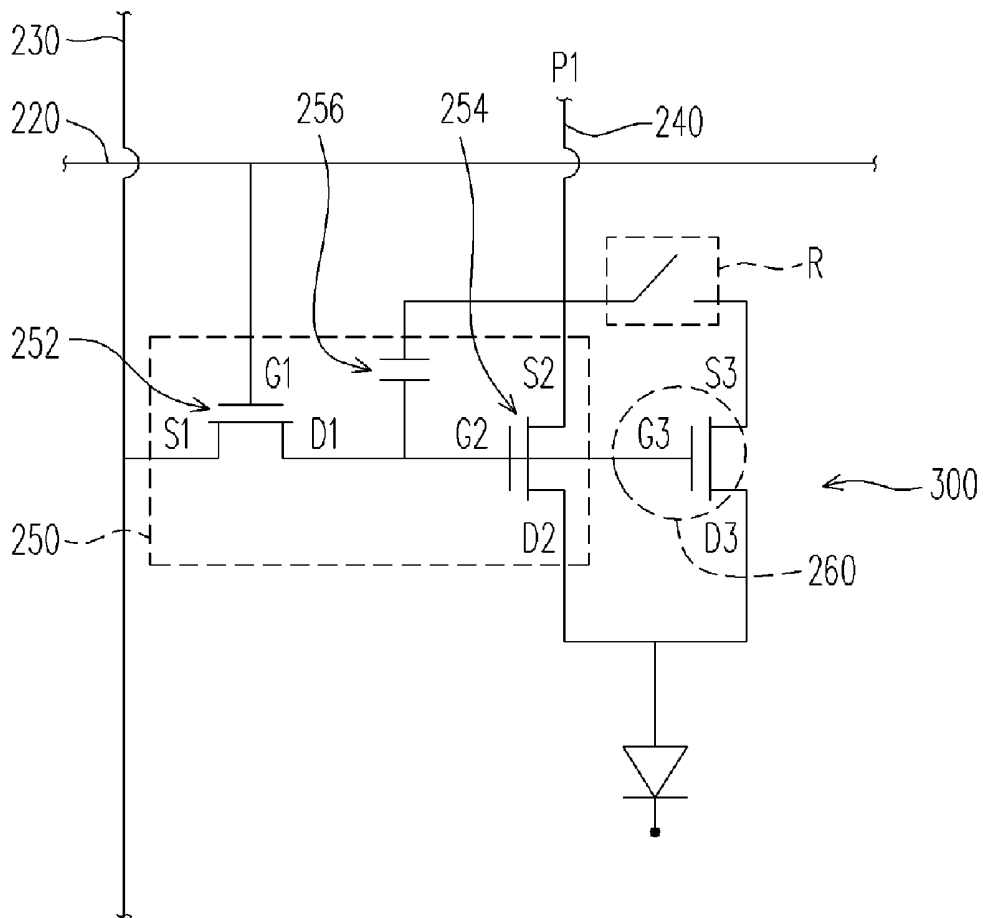

FIG. 9A

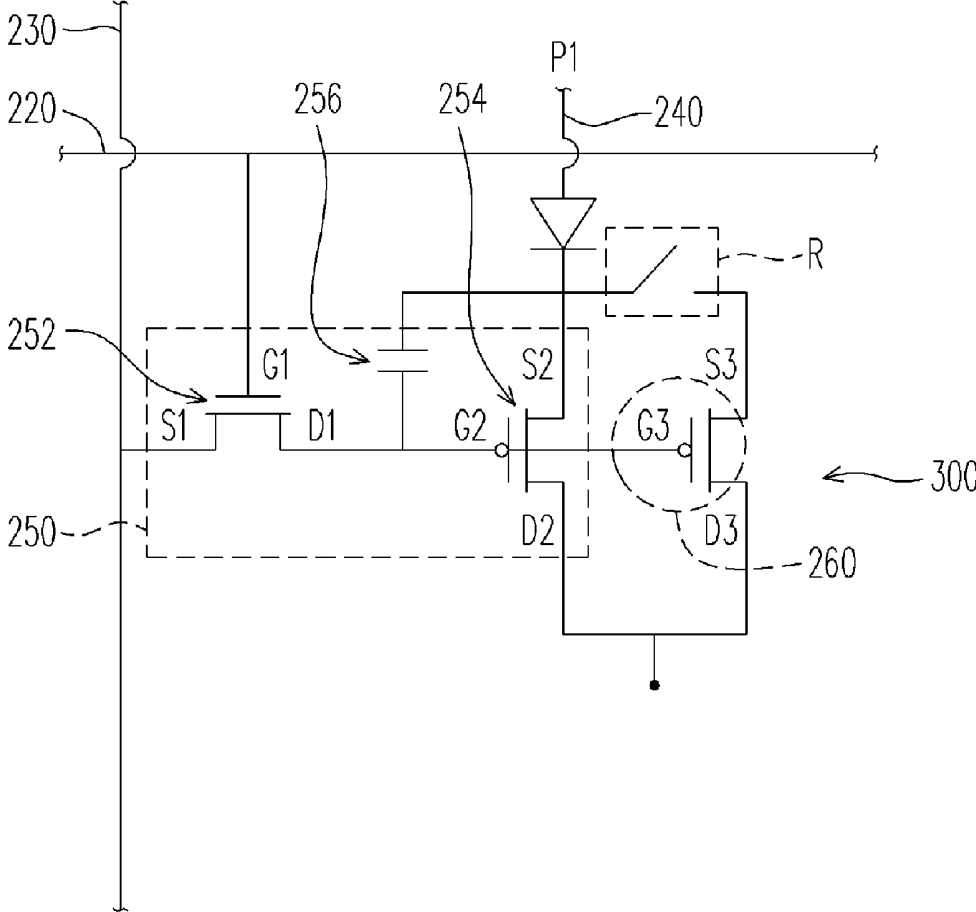

FIG. 9C

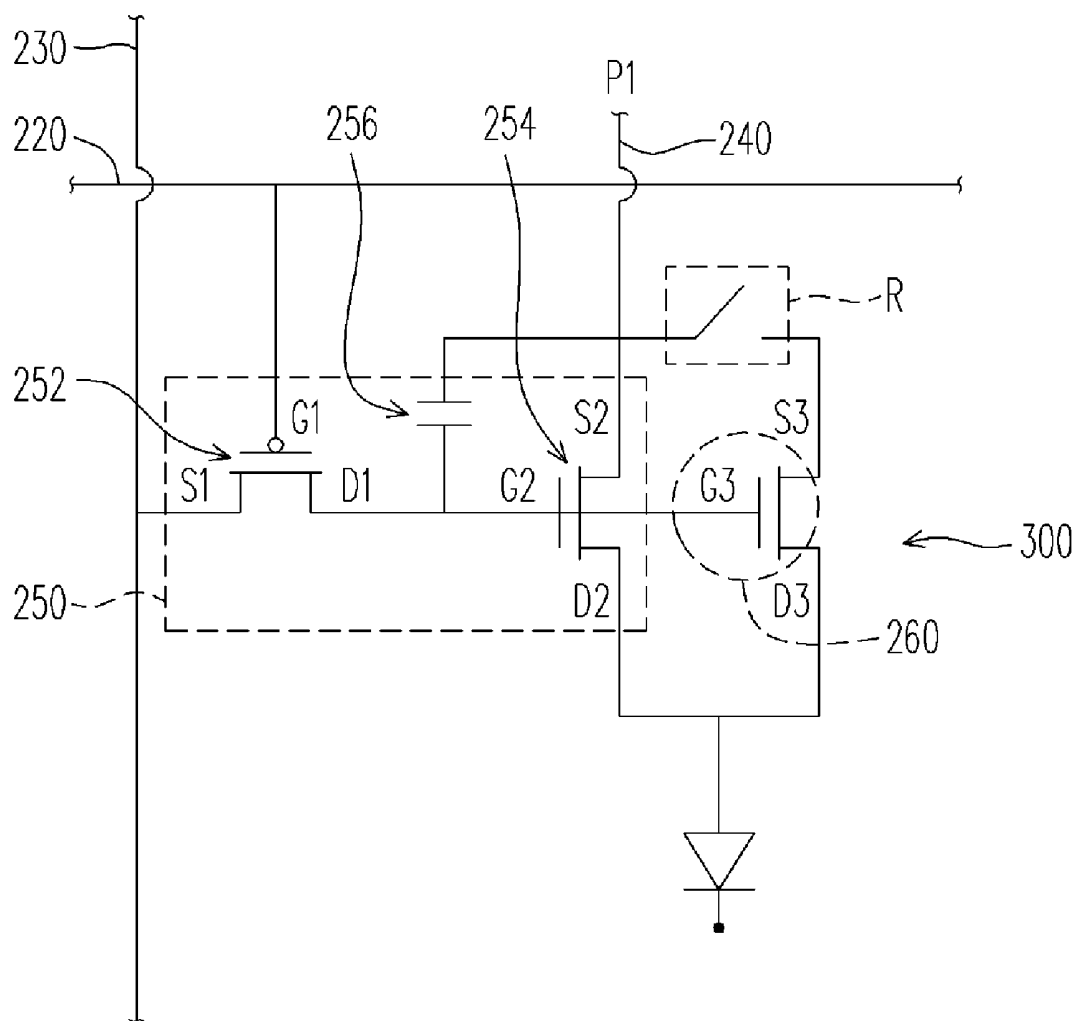

FIG. 9D

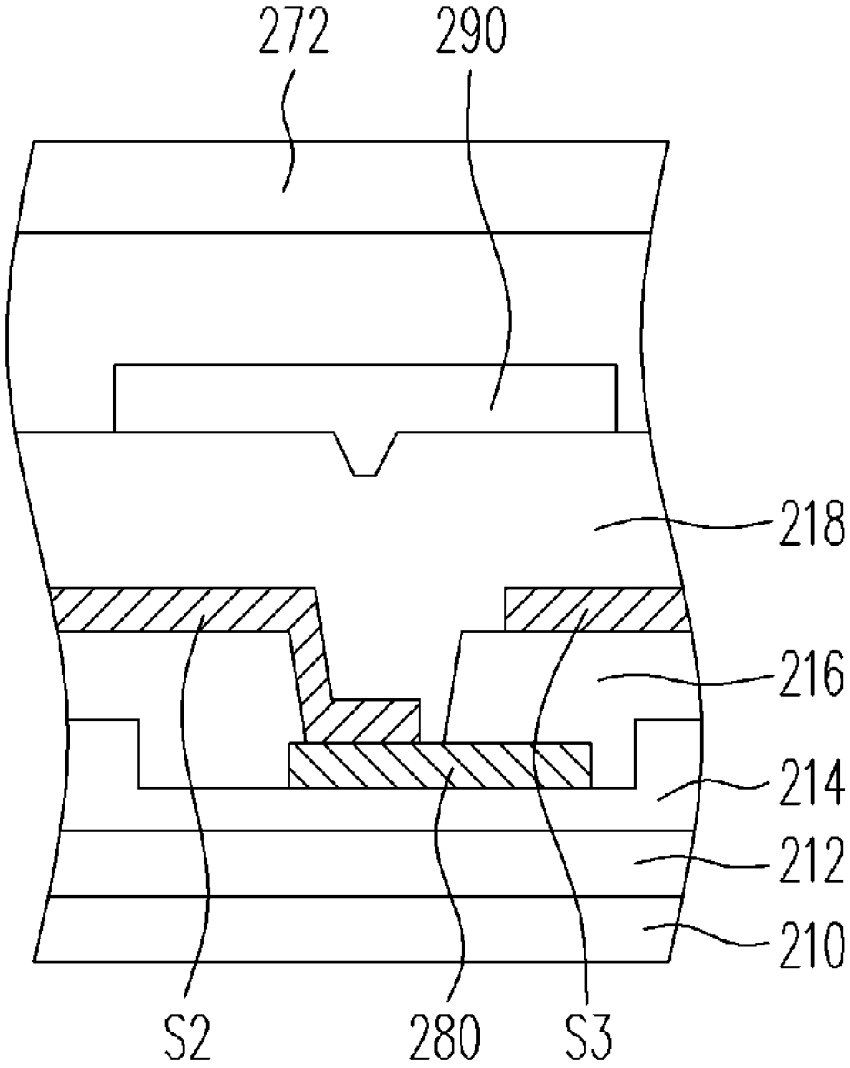

FIG. 10

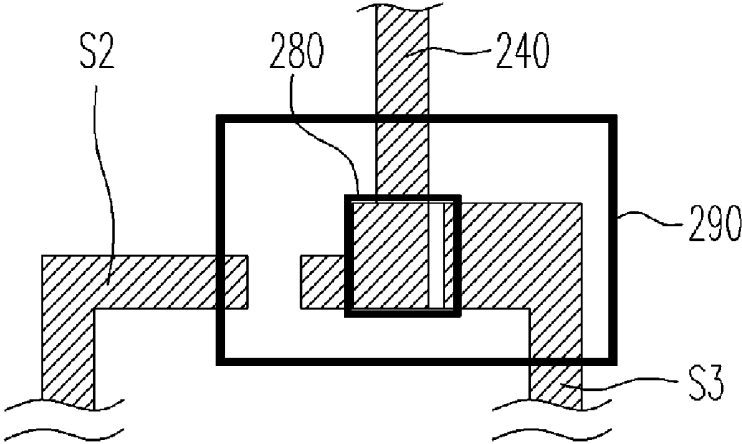

FIG. 11A

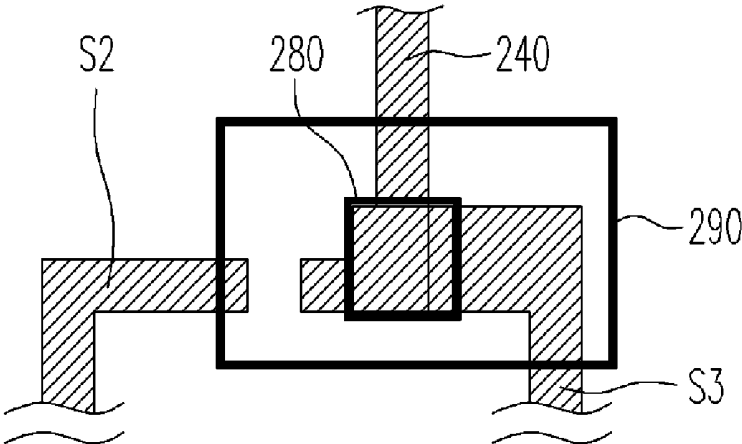

FIG. 11B

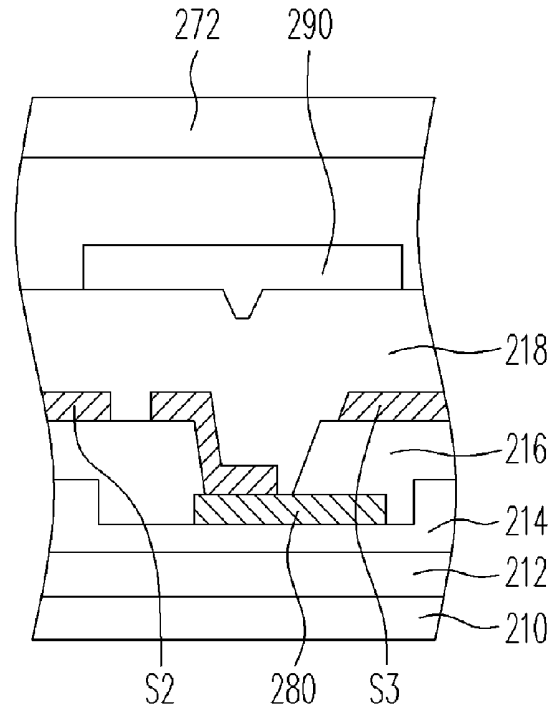

FIG. 12A

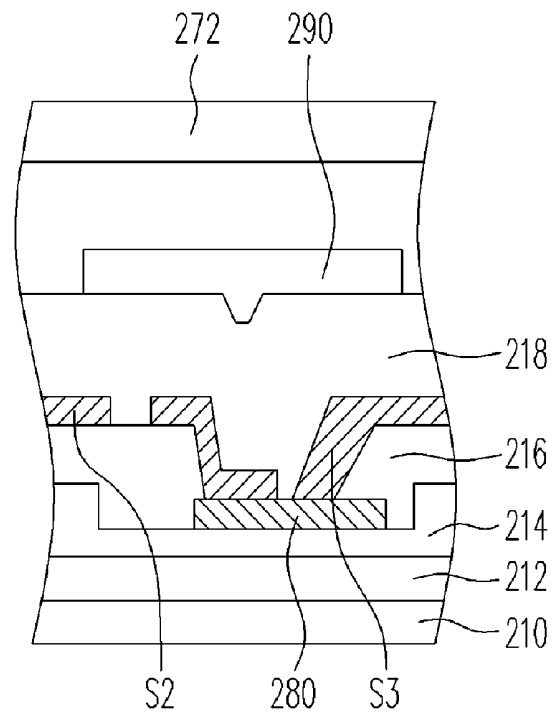

FIG. 12B

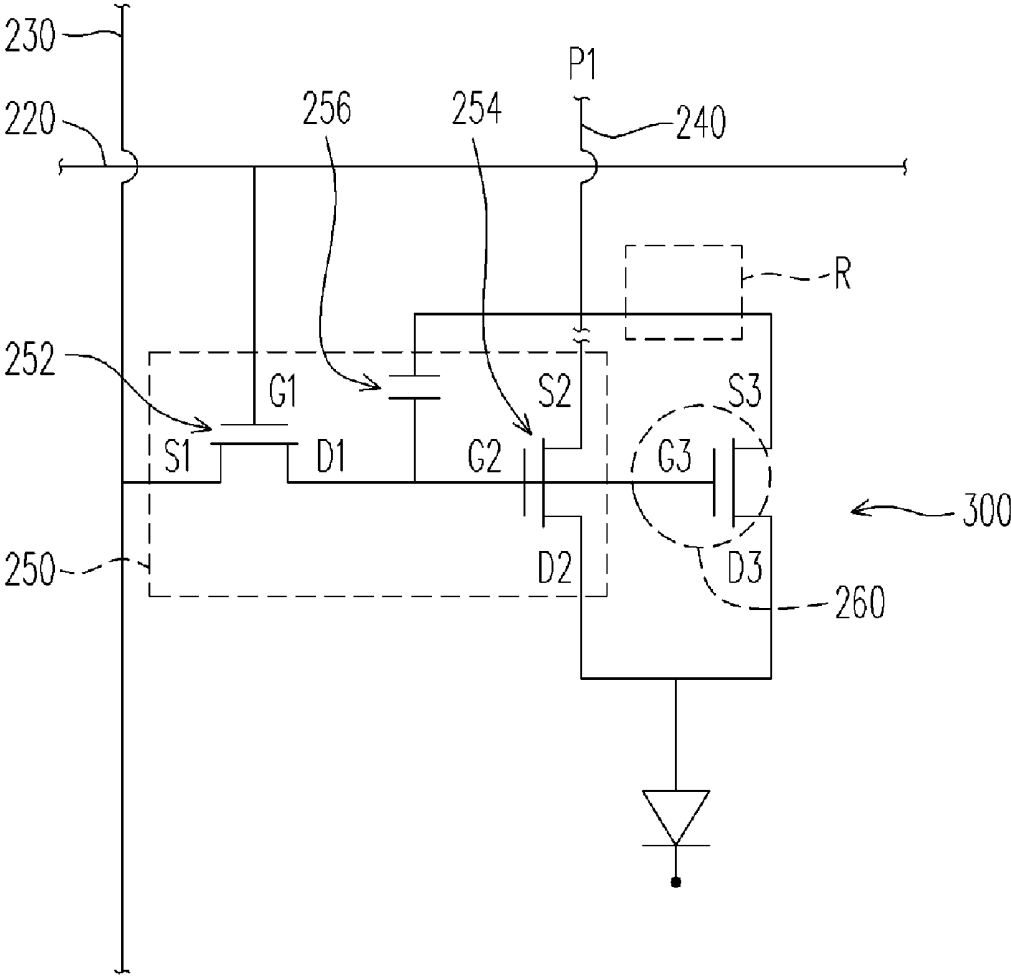

FIG. 13

**PIXEL STRUCTURE, ORGANIC
ELECTRO-LUMINESCENCE DISPLAYING
UNIT AND REPAIRING METHOD THEREOF**

**CROSS-REFERENCE TO RELATED
APPLICATION**

[0001] This application claims the priority benefit of Taiwan application serial no. 95100056, filed on Jan. 2, 2006. All disclosure of the Taiwan application is incorporated herein by reference.

BACKGROUND OF THE INVENTION

[0002] 1. Field of Invention

[0003] The present invention relates to a pixel structure and a repairing method thereof. More particularly, the present invention relates to an organic electro-luminescence displaying unit and a repairing method thereof.

[0004] 2. Description of Related Art

[0005] The rapid progress of the multiple media industry mostly benefits from the rapid development of semiconductors or display devices. For the display devices, as the flat panel display has advanced features such as high image quality, high space utilization efficiency, low power consumption, and no radiation, etc., it has become the main stream in the market. The flat panel display in the current market includes liquid crystal display (LCD), organic electro-luminescence display, and plasma display panel (PDP), etc. As the organic electro-luminescence display has advantages such as no viewing angle limit, low fabrication cost, high response speed (about hundreds times of an LCD), power saving, direct current drive, wide range of working temperature, and small volume, etc., it has great developing potential.

[0006] FIG. 1 is a schematic diagram of a circuit of a conventional organic electro-luminescence display. Referring to FIG. 1, the conventional organic electro-luminescence display 100 includes a substrate 110, a plurality of scan lines 120, a plurality of data lines 130, a plurality of power lines 140 and a plurality of display units 150. The scan lines 120 and the data lines 130 are disposed upon the substrate 110, so as to drive the corresponding display units 150, and the display units 150 are electrically connected to a power P through the power lines 140.

[0007] As shown in FIG. 1, the display unit 150 includes a switching thin film transistor (switching TFT) 152, a driving TFT 154, an organic electro-luminescence device 156 and a capacitor 158. In FIG. 1, the scan line 150 is electrically connected to a gate 152a of the switching TFT 152, and the data line 130 is electrically connected to a source 152b of the switching TFT 152, and a drain 152c of the switching TFT 152 is electrically connected to the gate 154a of the driving TFT 154. Moreover, the source 154b of the driving TFT 154 is electrically connected to the power line 140, and the drain 154c of the driving TFT 154 is electrically connected to the organic electro-luminescence device 156. In addition, the capacitor 158 is electrically connected between the gate 154a of the driving TFT 154 and the power line 140.

[0008] In detail, after the switching TFT 152 is turned on by the output voltage of the scan line 120, the data line 130 can transmit the voltage signal to the gate 154a of the driving TFT 154, so as to activate the driving TFT 154. Accordingly, the power can be provided to the organic

electro-luminescence device 156 through the power line 140 and the driving TFT 154, so that the organic electro-luminescence device 156 can display. Moreover, the voltage signal transmitted through the data line 130 can control the channel (not shown) of the driving TFT 154, so as to further control the amount of the current passing through the driving TFT 154. Accordingly, the luminescence intensity of the organic electro-luminescence device 156 is controlled appropriately, so that the organic electro-luminescence display 100 can display correct images.

[0009] In FIG. 1, the driving TFT 154 is an important role in the display unit 150. When the fabrication of the driving TFT 154 fails due to the neglect in fabricating process, the display quality of the entire organic electro-luminescence display 100 will be deteriorated significantly.

SUMMARY OF THE INVENTION

[0010] Accordingly, the present invention is directed to provide a repairable pixel structure, which keeps the possibility of repairing so as to avoid failure of the pixel structure.

[0011] Another aspect of the present invention is to provide a repairable organic electro-luminescence display unit, which keeps the possibility of repairing so as to avoid failure of the pixel structure.

[0012] Another aspect of the present invention is to provide a repairing method for the pixel structure, so as to avoid the problem that the pixel structure can not display normally because of the neglect in the fabricating process.

[0013] Another aspect of the present invention is to provide a repairing method for the organic electro-luminescence display unit, so as to avoid the problem that the pixel structure can not display normally due to the neglect in the fabricating process.

[0014] In order to achieve the above and other aspects, the present invention provides a pixel structure, which is suitable for electrically connected to a scan line, a data line and a power line. The pixel structure includes a current control unit, a pixel electrode and a redundant active device. The current control unit is electrically connected to the scan line, the data line and the power line. Moreover, the pixel electrode is electrically connected to the current control unit, and the redundant active device is electrically connected to the pixel electrode and the current control unit, and the redundant active device is electrically insulated from the power line.

[0015] The present invention provides an organic electro-luminescence display unit, which is suitable for electrically connected to a scan line, a data line and a power line. The organic electro-luminescence display unit includes the abovementioned pixel structure, an organic electro-luminescence layer and an electrode layer. The organic electro-luminescence layer is disposed above the pixel electrode, and the electrode layer is disposed above the organic electro-luminescence layer.

[0016] The present invention provides a method of repairing the pixel structure, suitable for repairing the above-described pixel structure. The method for repairing the pixel structure includes the following steps: first, cutting an electrical connection between the current control unit and the power line; then after, the power line is electrically connected to the redundant active device, so that the current control unit and the redundant active device can control the current provided by the power line.

[0017] The present invention provides a method of repairing the organic electro-luminescence display unit, suitable for repairing the above-mentioned organic electro-luminescence display unit. The method for repairing the organic electro-luminescence display unit includes the following steps: first, cutting an electrical connection between the current control unit and the power line; then, the power line is electrically connected to the redundant active device, so that the current control unit and the redundant active device can control the current passing through the organic electro-luminescence layer.

[0018] As the organic electro-luminescence display unit and the pixel structure of the present invention have the redundant active device electrically insulated from the power line, therefore, when the second active device fails, the redundant active device can substitute the invalid second active device by repairing mechanism (for example, laser cutting, laser welding), so that the organic electro-luminescence display unit and the pixel structure can normally display.

[0019] In order to make the aforementioned and other objects, features and advantages of the present invention comprehensible, a preferred embodiment accompanied with figures is described in detail below.

[0020] It is to be understood that both the foregoing general description and the following detailed description are exemplary, and are intended to provide further explanation of the invention as claimed.

BRIEF DESCRIPTION OF THE DRAWINGS

[0021] The accompanying drawings are included to provide a further understanding of the invention, and are incorporated in and constitute a part of this specification. The drawings illustrate embodiments of the invention and, together with the description, serve to explain the principles of the invention.

[0022] FIG. 1 is a schematic diagram of the circuit of a conventional organic electro-luminescence display.

[0023] FIG. 2 is a schematic diagram of the circuit of the pixel structure according to the first embodiment of the present invention.

[0024] FIG. 3 is a schematic cross-sectional diagram of the pixel structure according to the first embodiment of the present invention.

[0025] FIG. 4 is a schematic local cross-sectional diagram of the repairing region R shown in FIG. 2.

[0026] FIGS. 5A-5B are the schematic diagrams of the repairing process of the repairing region R shown in FIG. 2.

[0027] FIGS. 6A-6B are the schematic cross-sectional diagrams showing the repairing process of the repairing region R shown in FIG. 2.

[0028] FIG. 7 is a schematic diagram of the circuit after the pixel structure is repaired according to the first embodiment of the present invention.

[0029] FIG. 8 is a schematic cross-sectional diagram of the organic electro-luminescence display unit according to the second embodiment of the present invention.

[0030] FIG. 9A is a schematic diagram of the circuit of the organic electro-luminescence display unit according to the second embodiment of the present invention.

[0031] FIGS. 9B-9D are the schematic diagrams of the circuit of another type of organic electro-luminescence display unit according to the second embodiment of the present invention.

[0032] FIG. 10 is a schematic cross-sectional diagram of the repairing region R shown in FIG. 9A.

[0033] FIGS. 11A-11B are schematic diagrams of the repairing process of the repairing region R shown in FIG. 9A.

[0034] FIGS. 12A-12B are schematic cross-sectional diagrams of the repairing process of the repairing region R shown in FIG. 9A.

[0035] FIG. 13 is a schematic diagram of the circuit after the organic electro-luminescence display unit is repaired according to the second embodiment of the present invention.

DESCRIPTION OF EMBODIMENTS

The First Embodiment

[0036] FIG. 2 is a schematic diagram of a circuit of the pixel structure according to the first embodiment of the present invention. Referring to FIG. 2, the pixel structure 200 of the present invention is electrically connected to a scan line 220, a data line 230 and a power line 240, and the power line 240 is electrically connected to a power P1. The pixel structure 200 of the present invention includes a current control unit 250, a redundant active device 260 and a pixel electrode 270. The current control unit 250 is electrically connected to the scan line 220, the data line 230 and the power line 240. In addition, the pixel electrode 270 is electrically connected to the current control unit 250. The redundant active device 260 is electrically connected to the pixel electrode 270 and the current control unit 250. It is noted that the redundant active device 260 is electrically insulated from the power line 240. In the present invention, the redundant active device 260 is normally electrically insulated from the power line 240 when the current control unit 250 operates normally. When the current control unit 250 fails, the redundant active device 260 may be switched to electrically connected to the current control unit 250 by laser repairing process, so as to ensure that the pixel structure 200 can operate normally.

[0037] In detail, the scan line 220 and the data line 230 can transmit the signal to the current control unit 250, so that the current control unit 250 can control the current provided to the pixel electrode 270 from the power P1. It is noted that the current control unit 250 may be the common design of two transistors and one capacitor, namely the 2T1C in the industry, the design of three transistors and one capacitor (3T1C), the design of three transistors and two capacitor (3T2C), or other device assembly that can suitably control the current, which are not limited here.

[0038] In one embodiment, the current control unit 250 may include a first active device 252, a second active device 254 and one capacitor 256. In detail, the gate G1 of the first active device 252 is electrically connected to the scan line 220, and the source S1 of the first active device 252 is electrically connected to the data line 230. Moreover, the voltage signal transmitted through the scan line 220 can turn on the first active device 252, and the voltage signal transmitted through the data line 230 can be transmitted to the second active device 254 through the first active device 252.

[0039] Moreover, the gate G2 of the second active device 254 is electrically connected to the drain D1 of the first active device 252, and the source S2 of the second active device 254 is electrically connected to the power line 240. In addition, the capacitor 256 is electrically connected between the gate G2 of the second active device 254 and the power line 240. It can be learned clearly from FIG. 2 that the current control unit 250 is electrically connected to the pixel electrode 270, and the current control unit 250 can control the size of the current input to the pixel electrode 270. In detail, the voltage signal transmitted through the data line 230 can control the channel of the second active device 254, so that the amount of the current transmitted to the pixel electrode 270 through the second active device 254 can be controlled. In addition, the redundant active device 260 is electrically connected to the pixel electrode 270 and the current control unit 250. It is noted that the redundant active device 260 is electrically insulated from the power line 240. In other words, the current can not be transmitted to the redundant active device 260 through the power line 240.

[0040] FIG. 3 is a schematic cross-sectional diagram of the pixel structure according to the first embodiment of the present invention. Referring to FIG. 3, the first active device 252, the second active device 254, and the abovementioned redundant active device 260 can apply the top gate transistor. The redundant active device 260 can select the same device as the second active device 254. In other words, the redundant active device 260 can be fabricated above the substrate 210 together with the second active device 254 by the same fabrication process, so that no additional fabrication process is needed to make the redundant active device 260. In general, a buffer layer 212 is formed between the first active device 252, the second active device 254, the redundant active device 260 and the substrate 210; and a protection layer 218 covers above the first active device 252, the second active device 254, and the redundant active device 260.

[0041] In detail, the first active device 252 is, for example, a thin film transistor (TFT). The first active device 252 mainly includes a first gate G1, a first source S1, a first drain D1, and a first channel layer C1. In general, a gate insulation layer 214 is disposed between the first gate G1 and the first channel layer C1, and a dielectric layer 216 covers the first gate G1 and the gate insulation layer 214. In addition, the first source S1 and the first drain D1 are electrically connected to the first channel layer C1 through the contact openings 10, 11 disposed in the dielectric layer, respectively. The first gate G1 is electrically connected to the scan line 220 (as shown in FIG. 2), and the first source S1 is electrically connected to the data line 230 (as shown in FIG. 2).

[0042] The second active device 254 of the present invention is, for example, a TFT, and the second active device 254 mainly includes a second gate G2, a second source S2, a second drain D2, and a second channel layer C2. The second gate G2 is electrically connected to the first drain D1 (as shown in FIG. 2), and the second source S2 is electrically connected to the power line 240 (as shown in FIG. 2), and the second source S2 and the second drain D2 are electrically connected to the second channel layer C2 through the contact openings 12, 13, respectively. In addition, the second drain D2 is electrically connected to the pixel electrode 270 through a contact opening 14 disposed in the protection layer 218.

[0043] The redundant active device 260 of the present invention is, for example, a TFT, and the redundant active device 260 mainly includes a third gate G3, a third source S3, a third drain D3, and a third channel layer C3. The third gate G3 is electrically connected to the first drain D1. It is noted that the third source S3 is electrically insulated from the power line 240 (as shown in FIG. 2), and the third drain D3 is electrically connected to the pixel electrode 270 (as shown in FIG. 2).

[0044] It is noted that all of the first active device 252, the second active device 254 and the redundant active device 260 can be N type TFTs made by nMOS fabrication process. Of course, it is not limited here, and all of the first active device 252, the second active device 254 and the redundant active device 260 can also be P type TFTs made by PMOS fabrication process. In addition, the first active device 252 can also be an N type TFT made by nMOS fabrication process, and both of the second active device 254 and the redundant active device 260 can be P type TFTs made by PMOS fabrication process; of course, the first active device 252 can also be a P type TFT made by PMOS fabrication process, and both of the second active device 254 and the redundant active device 260 can be N type TFTs made by nMOS fabrication process.

[0045] The material of the pixel electrode 270 is, for example, transparent material such as indium tin oxide (ITO) or indium zinc oxide (IZO), etc., and the pixel structure 200 is suitable for the bottom emission OLED (to be described in the second embodiment). When the pixel electrode 270 is a reflective material, the pixel structure 200 may be suitable for a top emission OLED. Thus, the description of the pixel structure 200 of the present invention is primarily completed.

[0046] FIG. 4 is a schematic cross-sectional diagram of the repairing region R shown in FIG. 2. Referring to FIG. 4, the pixel structure 200 of the present embodiment may further include a repairing conductive layer 280, and the repairing conductive layer 280 is electrically connected to the power line 240 (as shown in FIG. 2) through the second source S2, and a partial region of the third source S3 may be disposed above the repairing conductive layer 280. It can be learned clearly from FIG. 4 that the redundant active layer 260 of the present invention is electrically insulated from the repairing conductive layer 280.

[0047] When inferior fabrication or damage happens in the fabrication of the second active device 254, the following repairing process can be performed:

[0048] FIG. 5A is a schematic diagram of the repairing process of the repairing region R shown in FIG. 2. Referring to FIG. 2 and FIG. 5A, the electrical connection between the current control unit 250 and the power line 240 is cut off. In more detail, the current control unit 250 is electrically insulated from the power line 240 by cutting the second source S2 and the power line 240, and the cutting method is, for example, laser cutting. Referring to FIG. 6A, the method of separating the second source S2 and the power line 240 is, for example, by laser transiting the back surface (the surface of the substrate 210 without device) of the substrate 210 so as to cut the second source S2 and the power line 240.

[0049] FIG. 5B is a schematic diagram of the repairing process of the repairing region R shown in FIG. 2. Referring to FIG. 2 and FIG. 5B simultaneously, the power line 240 is electrically connected to the redundant active device 260 so that the current provided by the power line 240 can be

controlled by the current control unit **250** and the redundant active device **260**. Referring to FIG. 6B, the third source **S3** of the redundant active device **260** is electrically connected to the power line **240** by electrically connecting with the repairing conductive layer **280**, and the method of connecting the third source **S3** and the repairing conductive layer **280** is, for example, laser welding.

[0050] FIG. 7 is a schematic diagram of the circuit after the pixel structure is repaired according to the first embodiment of the present invention. Referring to FIG. 7, the repairing method has the redundant active device **260** electrically connected to the power line **240** so as to substitute the second active device **254**, and further to keep the original function of the entire pixel structure **200**.

[0051] Referring to FIG. 4, the pixel structure **200** of the present invention may further include a block layer **290**, disposed above the repairing conductive layer **280**, a partial region of the second source **S2**, and a partial region of the third source **S3**. The block layer **290** has a coverage range of is substantially greater than the coverage range of the repairing conductive layer **280**. In other words, the area of the block layer **290** is substantially greater than that of the repairing conductive layer **280**. In detail, the main function of the block layer **290** is to block the laser radiated from the back surface of the substrate **210** when the pixel structure **200** is repaired by laser, and further to avoid the laser damaging other film layers that do not need to be repaired. It is noted that in the fabrication process of the organic electro-luminescence display unit, if inferior fabrication happens in the fabrication process of the pixel structure **200**, the pixel structure **200** can be repaired at once. Accordingly, it can avoid the inferior pixel structure **200** being continuously performed in the successive fabrication process, so that the fabrication cost is saved.

The Second Embodiment

[0052] FIG. 8 is a schematic cross-sectional diagram of the organic electro-luminescence display unit according to the second embodiment of the present invention, and FIG. 9A is a schematic diagram of the circuit of the organic electro-luminescence display unit according to the second embodiment of the present invention. Referring to FIG. 8 and FIG. 9A simultaneously, the organic electro-luminescence **300** of the present invention includes a pixel structure **200**, an organic electro-luminescence layer **272**, and an electrode layer **274**. The pixel structure **200** has been disclosed clearly in the first embodiment, the organic electro-luminescence layer **272** is disposed above the pixel electrode **270**, and the electrode layer **274** is disposed above the organic electro-luminescence layer **272**.

[0053] The pixel electrode **270**, the organic electro-luminescence layer **272** and the electrode **274** can form an organic electro-luminescence unit. In detail, when the material of the pixel electrode **270** is, for example, a reflective material, the electrode layer **274** is transparent material such as ITO, or IZO, etc., so that the organic electro-luminescence display unit (OLED) **300** is a top emission OLED **300**.

[0054] When the material of the pixel electrode **270** is, for example, transparent material such as ITO, or IZO, etc., the electrode layer **274** is a reflective material, and the organic electro-luminescence display unit **300** is a bottom emission OLED **300**.

[0055] The first active device **252**, the second active device **254** and the redundant active device **260** can be N type TFTs made by nMOS fabrication process. Of course, it is not limited here, and all of the first active device **252**, the second active device **254** and the redundant active device **260** can also be P type TFTs made by PMOS fabrication process as shown in FIG. 9B; and the above-described organic electro-luminescence device is electrically connected between the second source **S2** and the power **P1**. Referring to FIG. 9C, the first active device **252** can also be an N type TFT made by nMOS fabrication process, and both of the second active device **254** and the redundant active device **260** can be P type TFTs made by pMOS fabrication process. Referring to FIG. 9D, the first active device **252** can also be a P type TFT made by PMOS fabrication process, and both of the second active device **254** and the redundant active device **260** can be N type TFTs made by nMOS fabrication process.

[0056] It can be learned clearly from FIG. 8 that the second drain **D2** of the second active device **254** is electrically connected to the pixel electrode **270**, the organic electro-luminescence layer **272** and the electrode **274** (organic electro-luminescence diode) through the contact opening **14**. It is noted that the third source **S3** of the redundant active device **260** is electrically insulated from the power line **240**. Although it can not be shown in FIG. 8 and FIG. 9A, actually, the third drain **D3** of the redundant active device **260** is electrically connected to the pixel electrode **270**.

[0057] FIG. 10 is a local schematic cross-sectional diagram of the repairing region **R** shown in FIG. 9A. Referring to FIG. 10, the organic electro-luminescence display unit **300** of the embodiment may further include a repairing conductive layer **280**, and the repairing conductive layer **280** is electrically connected to the power line **240**. Moreover, the second source **S2** is electrically connected to the power line **240** through the repairing conductive layer **280**, and the repairing conductive layer **280** is electrically connected to the power line **240** through the second source **S2** (as shown in FIG. 9A), and a partial region of the third source **S3** is disposed above the repairing conductive layer **280**. It can be learned clearly from FIG. 10 that the redundant active device **260** of the present invention is electrically insulated from the repairing conductive layer **280**.

[0058] When an inferior fabrication or damage happens in the fabrication of the second active device **254** (as shown in FIG. 9A), the following repairing process can be performed:

[0059] FIG. 11A is a schematic diagram of the repairing process of the repairing region **R** shown in FIG. 9A. Referring to FIG. 9A and FIG. 11A simultaneously, the electrical connection between the current control unit **250** and the power line **240** is cut off. In detail, the current control unit **250** is electrically insulated from the power line **240** by cutting the second source **S2** and the power line **240**, and the cutting method is, for example, laser cutting. Referring to FIG. 12A, the method of separating the second source **S2** and the power line **240** is, for example, by laser transiting the back surface (the surface of the substrate **210** without device) of the substrate **210** so as to cut the second source **S2** and the power line **240**.

[0060] FIG. 11B is a schematic diagram of the repairing process of the repairing region **R** shown in FIG. 9A. Referring to FIG. 9A and FIG. 11B simultaneously, the power line **240** is electrically connected to the redundant active device

260 so that the current provided by the power line **240** can be controlled by the current control unit **250** and the redundant active device **260**. Referring to FIG. 12B, the third source **S3** of the redundant active device **260** is electrically connected to the power line **240** by electrically connecting with the repairing conductive layer **280**, and the method of connecting the third source **S3** and the repairing conductive layer **280** is, for example, laser welding.

[0061] FIG. 13 is a schematic diagram of the circuit after the pixel structure is repaired according to the second embodiment of the present invention. In FIG. 13, the above-mentioned repairing method has the redundant active device **260** electrically connected to the power line **240** so as to substitute the second active device **254**, and further to keep the original function of the organic electro-luminescence display unit **300**.

[0062] In summary, the organic electro-luminescence display unit and the pixel structure of the present invention have the redundant active device and the repairing conductive layer electrically insulated from the power line. When the second active device fails, the second active device can be electrically insulated from the power line by the repairing method of the organic electro-luminescence display unit and the repairing method of the pixel structure of the present invention; and the power line can be electrically connected to the redundant active device through the repairing conductive layer. Accordingly, the redundant active device of the present invention can substitute the inferior second active device so as to recover the normal function of the pixel structure, and thus the organic electro-luminescence display unit can display normally. The redundant active device of the present invention can be made together with the second active device; therefore, no additional fabrication process is needed for the redundant device. After the fabrication process of the pixel structure is completed, if an inferior fabrication of the pixel structure is found, the pixel structure can be repaired at once. Accordingly, it can avoid the inferior pixel structure being continuously processed in the successive fabrication process, so that the fabrication cost can be saved.

[0063] It will be apparent to those skilled in the art that various modifications and variations can be made to the structure of the present invention without departing from the scope or spirit of the invention. In view of the foregoing, it is intended that the present invention cover modifications and variations of this invention provided they fall within the scope of the following claims and their equivalents.

What is claimed is:

1. A pixel structure electrically connected to a scan line, a data line and a power line, comprising:

a current control unit electrically connected to the scan line, the data line and the power line;

a pixel electrode electrically connected to the current control unit; and

a redundant active device electrically connected to the pixel electrode and the current control unit and electrically insulated from the power line.

2. The pixel structure of claim 1, wherein the current control unit comprises:

a first active device having a first gate, a first source, and a first drain, wherein the first gate is electrically connected to the scan line, and the first source is electrically connected to the data line;

a second active device having a second gate, a second source, and a second drain, wherein the second gate is electrically connected to the first drain, the second source is electrically connected to the power line, and the second drain is electrically connected to the pixel electrode; and

a capacitor electrically connected between the second gate and the power line.

3. The pixel structure of claim 2, wherein the first active device is an N type thin film transistor (TFT) or a P type TFT.

4. The pixel structure of claim 2, wherein the second active device is an N type TFT or a P type TFT.

5. The pixel structure of claim 1, wherein the redundant active device has a third gate, a third source, and a third drain, wherein the third gate is electrically connected to the first drain, the third source is electrically insulated from the power line, and the third drain is electrically connected to the pixel electrode.

6. The pixel structure of claim 5, wherein the redundant active device is an N type TFT or a P type TFT.

7. The pixel structure of claim 5, further comprising a repairing conductive layer electrically connected to the power line, wherein the second source is electrically connected to the power line through the repairing conductive layer, and a partial region of the third source is disposed above the repairing conductive layer.

8. The pixel structure of claim 7, further comprising a block layer disposed above the repairing conductive layer, a partial region of the second source, and a partial region of the third source.

9. The pixel structure of claim 8, wherein the block layer has a coverage range substantially greater than that of the repairing conductive layer.

10. An organic electro-luminescence display unit electrically connected to a scan line, a data line and a power line, comprising:

a current control unit electrically connected to the scan line, the data line and the power line;

a pixel electrode electrically connected to the current control unit;

a redundant active device electrically connected to the pixel electrode and the current control unit and electrically insulated from the power line;

an organic electro-luminescence layer disposed above the pixel electrode; and

an electrode layer disposed above the organic electro-luminescence layer.

11. The organic electro-luminescence display unit of claim 10, wherein the current control unit comprises:

a first active device having a first gate, a first source, and a first drain, wherein the first gate is electrically connected to the scan line, and the first source is electrically connected to the data line;

a second active device having a second gate, a second source, and a second drain, wherein the second gate is electrically connected to the first drain, and the second source is electrically connected to the power line, and the second drain is electrically connected to the pixel electrode; and

a capacitor electrically connected between the second gate and the power line.

12. The organic electro-luminescence display unit of claim 11, wherein the first active device is an N type TFT or a P type TFT.

13. The organic electro-luminescence display unit of claim 11, wherein the second active device is an N type TFT or a P type TFT.

14. The organic electro-luminescence display unit of claim 10, wherein the redundant active device has a third gate, a third source, and a third drain, wherein the third gate is electrically connected to the first drain, the third source is electrically insulated from the power line, and the third drain is electrically connected to the pixel electrode.

15. The organic electro-luminescence display unit of claim 14, wherein the redundant active device is an N type TFT or a P type TFT.

16. The organic electro-luminescence display unit of claim 14, further comprising a repairing conductive layer electrically connected to the power line, wherein the second source is electrically connected to the power line through the repairing conductive layer, and a partial region of the third source is disposed above the repairing conductive layer.

17. The organic electro-luminescence display unit of claim 16, further comprising a block layer disposed above the repairing conductive layer, a partial region of the second source, and a partial region of the third source.

18. The organic electro-luminescence display unit of claim 17, wherein the block layer has a coverage range substantially greater than that of the repairing conductive layer.

19. A method for repairing the pixel structure of claim 1, comprising:

cutting an electrical connection between the current control unit and the power line; and

electrically connecting the power line to the redundant active device, so that the current control unit and the redundant active device control the current provided by the power line.

20. The method of claim 19, wherein the electrical connection between the current control unit and the power line is cut through laser cutting.

21. The method of claim 19, wherein the power line and the redundant active device are electrically connected through laser welding.

22. A method for repairing an organic electro-luminescence display unit of claim 10, comprising:

cutting an electrical connection between the current control unit and the power line; and

electrically connecting the power line to the redundant active device, so that the current control unit and the redundant active device can control the current passing through the organic electro-luminescence.

23. The method of claim 22, wherein the electrical connection between the current control unit and the power line is cut through laser cutting.

24. The method of claim 22, wherein the power line and the redundant active device are electrically connected through laser welding.

* * * * *

专利名称(译)	像素结构，有机电致发光显示单元及其修复方法		
公开(公告)号	US20070152567A1	公开(公告)日	2007-07-05
申请号	US11/309018	申请日	2006-06-09
[标]申请(专利权)人(译)	姚志文 LEE HUNG HSIN		
申请(专利权)人(译)	姚CHIH-WEN 李昕鸿		
当前申请(专利权)人(译)	姚CHIH-WEN 李昕鸿		
[标]发明人	YAO CHIH WEN LEE HSIN HUNG		
发明人	YAO, CHIH-WEN LEE, HSIN-HUNG		
IPC分类号	G09G3/10 H01J1/62		
CPC分类号	G09G3/3233 G09G2300/0842 G09G2330/08 H01L27/124 H01L27/3244 H01L2251/568 H01L27/3223		
优先权	095100056 2006-01-02 TW		
其他公开文献	US7642710		
外部链接	Espacenet USPTO		

摘要(译)

提供电连接到扫描线，数据线和电源线的像素结构。像素结构包括电流控制单元，像素电极和冗余有源器件。电流控制单元电连接到扫描线，数据线和电源线。像素电极电连接到电流控制单元。冗余有源器件电连接到像素电极和电流控制单元，冗余有源器件与电源线电绝缘。此外，还提供了一种有机电致发光显示单元及其修复方法。

